

# VIBROLL 55

## SINGLE DRUM COMPACT VIBRATING ROLLER

### TECHNICAL SPECIFICATION

#### WEIGHTS

OPERATING WEIGHT CE. CE	187KG
BASIC WEIGHT	185KG
STATIC LINEAR LOAD C.E CE	340KG/CM

#### DIMENSIONS

DRUM WORKING WIDTH	W 550mm
LENGTH	L 1470mm
WIDTH	B 660mm
HEIGHT	H 860mm
DRUM DIAMETER	D 440mm
DRUM WIDTH	W 550mm
SIDE CLEARANCE CLEARSIDE	WC 14mm
SIDE CLEARANCE DRIVESIDE	WD 77mm
CURB CLEARANCE CLEARSIDE	HC 186mm
CURB CLEARANCE DRIVESIDE	HD 120mm

#### ENGINE

ENGINE MANUFACTURE	HONDA
FUEL	UNLEADED

#### VIBRATION CHARACTERISITICS

VIBRATION FREQUENCY	75Hz
CENTRIFUGAL FORCE	807daN
NOMINAL AMPLITUDE	0.59mm

#### VIBRATOR DRIVE SYSTEM

MECHANICAL CENTRIFUGAL CLUTHC	
VEE BELT DRIVE	CLUTCH CUT IN SPEED
	1800 rev/min

#### SPRINKLER SYSTEM

GRAVITY FED WITH REGULATING BALL VALVE

#### CAPACITIES

FUEL	3.6L
WATER	4.8L
HYDRAULIC	1.5L

#### TRAILER

OVERALL LENGTH	1830mm
OVERALL WIDTH	1435mm
OVERALL HEIGHT	4400mm
UNLADEN WEIGHT	60kg
TYRE SIZE	4.80/4.00-8
TYRE PRESSURE	2.5 bar
TOWING EYE	50mm BALL

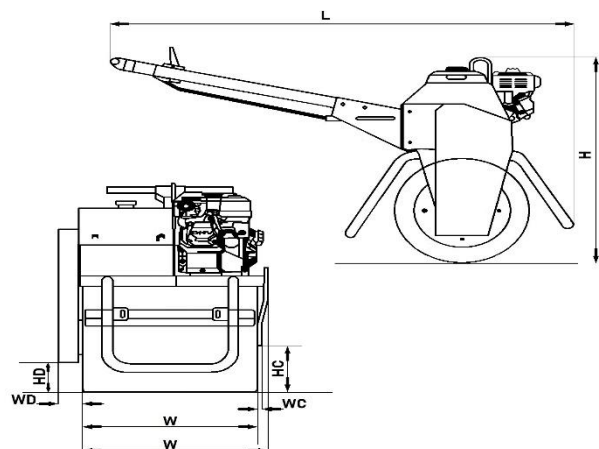

Plant & Engineering Services, Beare, Nr Exeter, Devon EX5 3JX

Tel : 01392 882220

Email: office@pesplant.co.uk